



MASSON MARINE SAS

5, rue Henri Cavallier

89100 St Denis Les Sens – France

+33 3 86 95 62 00

www.masson-marine.com

MM W18000 C



Co-axial, remote mount marine transmission

Maximum rated input: 3 765kW (5 047bhp)

Available for Continuous Duty applications

Description

- Robust design also withstands continuous duty in workboat applications.
- Fully works tested, reliable and simple to install.
- Design, manufacture and quality control standards comply with ISO 9001.
- Reverse reduction marine transmission with hydraulically actuated multi-disc clutches.
- Easy onboard maintenance.
- Compatible with all types of engines and propulsion systems. (Compatible for FPP)

Features

- Case hardened and precisely ground gear teeth for long life and smooth running.
- Output shaft thrust bearing designed to take maximum propeller thrust astern and ahead.
- Smooth and reliable hydraulic shifting with control lever for attachment of push-pull cable or other operating system.
- Suitable for twin engine installations (same ratio and torque capacity in ahead or astern mode)
- Emergency “get home” capability.
- Robust cast iron casing.
- Free standing.
- Oil cooler complete with fittings and flexible hoses.
- Integrated brackets.

Options

- Engine-matched torsional coupling.
- Propeller shaft flange and coupling bolt sets.
- Classification by all major Classification Societies on request.
- PTO (live or clutchable).
- Trolling valve for slow-speed drive.
- Shaft brake.
- Electric clutch control (24 VDC).

Ratings

Ratios	kW/rpm	Sample Power Capacities			Max rpm
		750 rpm	1000 rpm	1800 rpm	
2.457	2.525	1894	2525	-	1490
2.916	2.127	1595	2127	-	1770
3.461	1.792	1344	1792	3226	1800
3.975	1.560	1170	1560	2808	1800
4.418	1.404	1053	1404	2527	1800
4.922	1.260	945	1260	2268	1800
5.298	1.170	878	1170	2106	1800
5.711	1.086	815	1086	1955	1800
6.761	0.929	697	929	1672	1800
7.288	0.862	647	862	1552	1800

Dimensions

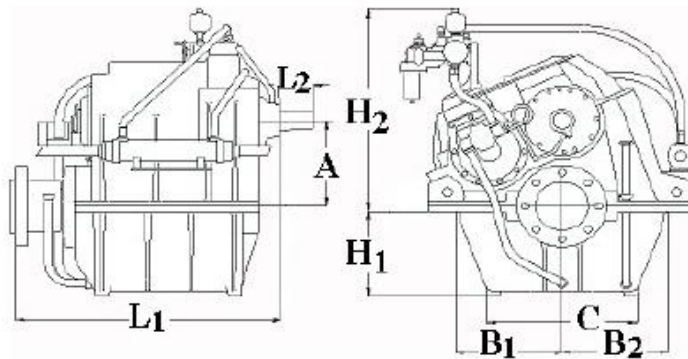

mm (inches)							
A	B ₁	B ₂	C	H ₁	H ₂	L ₁	L ₂
0	540	540	768	480	1143	1297	176
Weight kg				Oil Capacity Litres			
3650				150			

Output Coupling Dimensions

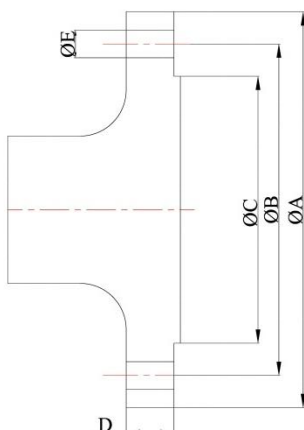

A	B	C	D	Bolt Holes	
				No.	Diameter (E) mm
mm	mm	mm	mm	8	37